

LUBRICATION ORDER

LO 5-6115-545-12

LI-00038G-12

(Supersedes LO5-6115-645-12, 24 October 1986)

20 January 1988

Approved for public release. Distribution is unlimited.

GENERATOR SET, DIESEL DRIVEN, 60 KW, 120/208-240/416V,
3 PHASE, 4 WIRE, 50-60 HERTZ, SKID MOUNTED, (TACTICAL
UTILITY) NSN 6115-00-118-1243 AND (TACTICAL PRECISE)
NSN 6115-00-118-1252 AND
GENERATOR SET, DIESEL DRIVEN, 60 KW, 120/208-240/416V,
3 PHASE, 4 WIRE, 400 HERTZ, SKID MOUNTED, (TACTICAL
PRECISE) NSN 6115-00-118-1253

Reference: TM5-6115-545-12 and C9100-1L

Hard time intervals and the related task-hour times are based on normal operation. The task-hour time specified is the time you need to do all the services prescribed for a particular interval. Change the interval if your lubricants are contaminated or if you are operating the equipment under adverse operating conditions, including longer-than-usual operating hours. The interval may be extended during periods of low activity. If extended, adequate preservation precautions must be taken.

On-condition (OC) intervals for oil changes shall be determined by the Army Oil Analysis Program (AOAP) laboratory and shall be applied unless otherwise notified.

Hard time oil change intervals will be applied in the event AOAP laboratory support is not available.

Clean fittings before lubricating. Lubricate points indicated by dotted arrow shaft on both sides of equipment. Clean parts with drycleaning SOLVENT (SD), type II or equivalent. Dry before lubricating. Drain crankcase when HOT. Fill and check level. The lowest level of maintenance authorized to lubricate a point is indicated by one of the following: (C) Operator/Crew; or (O) Organizational Maintenance.

You can help improve this publication. If you find any mistake or if you know of a way to improve the procedures, please let us know. your letter or DA Form 2028 (Recommended Changes to Publications and Blank Forms) should be mailed directly to: Commander, US Army Troop Support Command, ATTN: AMSTR-MCTS, 4300 Goodfellow Blvd, St. Louis, MO 63120-1798. A reply will be furnished to you.

LUBRICANT • INTERVAL

Hydraulic Filter (O) 1000
(See notes 5 & 6)

Hydraulic Sump Sight Gage (C) (check level) (See note 5) 100

Hydraulic Sump Fill and Drain Plugs (O) OHA 1000
(Drain and fill)
(See key & note 5)

Crankcase Oil Fill Cap and Level Gage. (C) (check level) (See key & note 4) OE/ 8 HDO

CAUTION: When EOA oil is used, check level more often.

Engine Oil Drain (O) on-condition AOAP analysis (Drain and fill) (See notes 7 & 3) OC 50 or 60D

Main Generator (Sealed bearings; no lubrication required)

INTERVAL • LUBRICANT

Engine Accessory Alternator (Sealed bearings; no lubrication required)

OC 300 or 6M Oil Filters (O) AOAP analysis (Disassemble, clean, and replace elements) (See notes 3, 7, & 8)

Starter (Sealed bearings; no lubrication required)

Air Cleaner, Dry Type (No lubrication required)

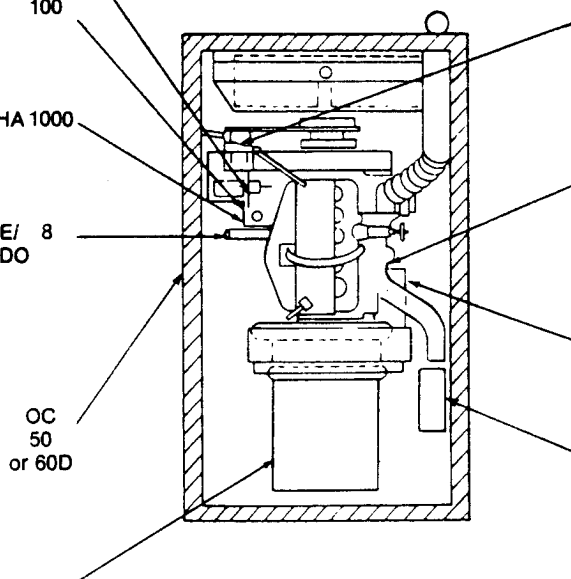

*The time specified is the time required to perform all services at the particular interval (On-condition or hard time).

* TOTAL TASK-HR		* TOTAL TASK-HR	
INTERVAL	TASK-HR	INTERVAL	TASK-HR
8	0.1	50H or 60D	0.6
100	0.1	1000	1.0

- KEY -

LUBRICANTS	CAPACITY	EXPECTED TEMPERATURES			INTERVALS
		ABOVE +32°F (ABOVE 0°C)	+40°F TO -10°F (+5°C TO -23°C)	0°F TO -65°F (-18°C TO -50°C)	
OE/HDO (MIL-L-2104D) LUBRICATING OIL, Engine Engine Crankcase with Filters Oil Can Points	26 qts (29.5L)	OE/HDO 30 OR OE/HDO 15-40	OE/HDO 10 OR OE/HDO 15-40	OE/A	Intervals given are in hours of normal operation
OE/A (MIL-H-46167) LUBRICATING OIL, Engine, Subzero					
OE/A (MIL-H-5606B) HYDRAULIC FLUID Hydraulic Tank, Filters and Lines	4 qts (3.8L)		OHA		

For arctic operation refer to FM 9-207

NOTES:

1. FOR OPERATION OF EQUIPMENT IN PROTRACTED COLD TEMPERATURES BELOW -10°F (-23°C). Remove lubricants prescribed in the key for temperatures above -10°F (-23°C). Clean parts with drycleaning SOLVENT (SD), type II or equivalent. Lubricate with lubricants specified in the key for temperatures 0°F to -65°F.

2. OIL CAN POINTS. Every 100 hours lubricate hinges, latches, control linkages, and all exposed adjusting threads with OE-HDO.

3. OIL FILTER. Every 300 hours remove filter element, clean housing, install new element, fill crankcase, place dead crank switch (S22) in the off (down) position, and crank engine for 15 seconds, then return dead crank switch to the on (up) position. Start and operate engine for 5 minutes, check for leaks, check crankcase oil level and bring to full mark. Oil filter replacement interval shall align with on-condition AOAP or hard time oil change requirements. See notes 7 and 8.

4. CRANKCASE. Crankcase level may be checked with the engine in either a static or operating condition.

5. SET DIFFERENCES. Used on precise generator sets only.

6. HYDRAULIC FILTER. Applicable to Precise sets only, that are not equipped with an electric governor. Disassemble hydraulic filter, renew element, and reassemble. Bring oil level to full, run for 15 minutes, check level and fill if necessary.

★ U.S. GOVERNMENT PRINTING OFFICE: 1988-201-419/80310

7. CRANKCASE OIL. A sample of the oil shall be sent to an AOAP laboratory for analysis at an interval of 50 hours or 60 days. Refer to TB 43-0210 for sampling requirements.

8. When AOAP laboratory support is not available, drain and refill crankcase oil at 300 hours or 6 months.

Copy of this Lubrication Order will remain with the equipment at all times; instructions contained herein are mandatory.

By Order of the Secretary of the Army:

CARL E. VUONO
General, United States Army
Chief of Staff

Official:

R. L. DILWORTH
Brigadier General, United States Army
The Adjutant General

DISTRIBUTION:

To be distributed in accordance with DA Form 12-25A, Operator and Unit Maintenance requirements for Generator Set, Diesel Driven, Tactical, Skid Mounted, 120/208V, 240/416V, 3PH, 4 Wire (50/60 HZ: MEP-006A, MEP-105A; 400HZ: MEP-115A).

020615-000